

Air Quality Management Plan

for the

Possum Brush Quarry

DA 283/97

Prepared in conjunction with:



R.W. CORKERY & CO. PTY. LIMITED

October 2023

Prepared by:

Pacific Blue Metal Pty Ltd
ABN: 45 050 224 250
PO Box 6
NABIAC NSW 2312

Telephone: (02) 6554 3206
Facsimile: (02) 6554 3250
Email: charlie@pacificbluemetal.com.au

In conjunction with:

R.W. Corkery & Co. Pty. Limited
Geological & Environmental Consultants
ABN: 31 002 033 712

Sydney Office:

North Tower Suite 12.01
1/5 Railway Street
Chatswood NSW 2067

Orange Office:

62 Hill Street
ORANGE NSW 2800

Brisbane Office:

Level 54
111 Eagle Street
BRISBANE QLD 4000

Telephone: (02) 9985 8511
Facsimile: (02) 6361 3622
Email: admin@rwcorkery.com

Ref No. 484/29

This Copyright is included for the protection of this document

COPYRIGHT

© Pacific Blue Metal Pty Ltd 2023

and

© R.W. Corkery & Co. Pty Limited 2023

All intellectual property and copyright reserved.

Apart from any fair dealing for the purpose of private study, research, criticism or review, as permitted under the Copyright Act, 1968, no part of this report may be reproduced, transmitted, stored in a retrieval system or adapted in any form or by any means (electronic, mechanical, photocopying, recording or otherwise) without written permission. Enquiries should be addressed to R.W. Corkery & Co. Pty Limited.

DOCUMENT CONTROL

Document Title	Air Quality Management Plan
Document Nbr.	484/29

Draft			
Version	Date	Distributed to	Comments Rec'd from – Date
0.00	n/a		

Final					
Version	Date	Approved By	Reviewed By	Section	Description
1.00	25/07/2016	Charlie Kennett General Manager	Stacey Tyack QSE Manager	All	Plan approved for submission to DPE
1.01	04/10/2016	Charlie Kennett General Manager	Stacey Tyack QSE Manager	All	Plan amended to address DPE comments received 12/09//16.
1.02	13/03/2017	Charlie Kennett General Manager	Stacey Tyack QSE Manager	All	Minor corrective editing including pages numbers and labels.
1.03	10/07/2017	Charlie Kennett General Manager	Stacey Tyack QSE Manager	Section 11.3	Location of dust monitors added as per DPE requirement 4/7/17.
2.00	03/01/2018	Charlie Kennett General Manager	Stacey Tyack QSE Manager	All	Full review triggered by Condition 5(4).
3.00	18/12/18	Charlie Kennett General Manager	Stacey Tyack QSE Manager	Section 11.1 Section 11.3 Section 11.6 Section 14	Adjusted number of years Section heading change Added Table 8 Amended monitoring frequency Amended monitoring frequency Amended complaints protocol
3.01	13/05/19	Charlie Kennett General Manager	Stacey Tyack QSE Manager	Section 14 Section 15	As per DPE email 13/05/19 - amended complaints protocol and incident reporting to better reflect the conditions of consent.
4.00	10/12/19	Charlie Kennett General Manager	Stacey Tyack QSE Manager	All Table 1 Section 4.4 Section 5.1	Removed all or parts of Sections 1,2,3,6,7,12-17 to EMS (generic information to all MP's). Altered order of contents. General editing Updated internal references Added additional data and discussion of results. Added new introduction.
4.01	02/09/20	Charlie Kennett General Manager	Stacey Tyack QSE Manager	Acronyms Table 1 Section 4.5 & Section 5.1 Section 5.4 Table 6 Section 6.6 Figure 6	Updated Updated internal references Residence on quarry owned land Record of weather check Reference to L&RMP Reference to Approved Methods for Sampling of Air Pollutants in New South Wales guideline. Inserted Air Quality Monitoring locations map
5.00	01/11/21	Charlie Kennett General Manager	Stacey Tyack QSE Manager	All Table 2	General Editing Update criteria from L to m ³ (as per EPL)
6.00	16/09/22	Charlie Kennett General Manager	Stacey Tyack QSE Manager	All Table 1 Section 6.2	General editing Updated reference to DPE Updated internal references Updated standards reference
7.00	12/10/23	Charlie Kennett General Manager	Stacey Tyack QSE Manager	Page 2	Updated RWC contact details

CONTENTS

	Page
1. INTRODUCTION	7
2. LEGAL AND OTHER REQUIREMENTS.....	9
2.1 DEVELOPMENT CONSENT	9
2.2 ENVIRONMENT PROTECTION LICENCE	12
3. OBJECTIVES AND OUTCOMES	13
4. BASELINE DATA	14
4.1 WIND ENVIRONMENT	14
4.2 AMBIENT AIR QUALITY	15
4.3 BACKGROUND PARTICULATE MATTER.....	15
4.4 DUST DEPOSITION DATA.....	16
4.5 SURROUNDING RESIDENCES	17
5. AIR QUALITY CONTROL MEASURES	18
5.1 INTRODUCTION.....	18
5.2 POTENTIAL AIR QUALITY IMPACTS.....	18
5.3 GREENHOUSE GAS EMISSIONS	18
5.4 DUST CONTROL PROCEDURES	19
6. AIR QUALITY MONITORING	20
6.1 INTRODUCTION.....	20
6.2 MONITORING EQUIPMENT	20
6.3 PARAMETERS AND ASSESSMENT CRITERIA	21
6.4 MONITORING FREQUENCY	21
6.5 DEPOSITED DUST MONITORING PROCEDURE	21
6.5.1 Introduction	21
6.5.2 Sampling Equipment.....	21
6.5.3 Sample Collection.....	22
6.5.4 Office Procedures	23
6.5.5 Field Procedures.....	23
6.5.6 Sample Despatch	24
6.5.7 Data Recording and Reporting	24
6.6 METEOROLOGICAL MONITORING	24

7.	EVALUATION OF COMPLIANCE.....	26
8.	CORRECTIVE AND PREVENTATIVE ACTIONS.....	27
9.	COMPLAINTS HANDLING AND RESPONSE	28
10.	INCIDENT REPORTING.....	29
11.	PUBLICATION OF ENVIRONMENTAL MONITORING INFORMATION.....	29
12.	PLAN REVIEW	29
13.	REFERENCES.....	29

FIGURES

Figure 1	Locality Plan.....	8
Figure 2	Calmet Seasonal Wind Roses – Quarry Site - 2014	14
Figure 3	Korora Time-series 24-hour Average PM ₁₀ and PM _{2.5} Concentrations– Oct 2005 to Jan 2006	15
Figure 4	Land Ownership and Residences.....	17
Figure 5	Typical deposited dust gauge	22
Figure 6	Air Quality Monitoring Locations	25

TABLES

Table 1	Development Consent Requirements Relating to Air Quality.....	9
Table 2	EPL 3393 Air Quality Concentration Limits.....	12
Table 3	Objectives and Key Performance Outcomes.....	13
Table 4	Impact Assessment Criteria for Airborne Particulates	15
Table 5	Depositional Dust Data 2017- 2019.....	16
Table 6	Dust Control Measures	19
Table 7	Background Air Quality Environment for Assessment Purposes.....	21

LIST OF ACRONYMS

AHD	Australian Height Datum
AS	Australian Standard
CCC	Community Consultation Committee
DA	Development Application
DPE	Department of Planning and Environment
Department	Department of Planning & Environment
EA	Environmental Assessment
ENCM	Environmental Noise Control Manual
EP&A Act	Environmental Planning and Assessment Act 1979
EPA	Environment Protection Authority
EPL	Environment Protection Licence
ERM	Environmental Resource Management Pty Ltd
GTCC	Greater Taree City Council (MidCoast Council as of 1 July 2016)
MCC	MidCoast Council
PBM	Pacific Blue Metal Pty Ltd
PM ₁₀	Particulate Matter <10µm in diameter
RPM	Runge Pincock Minarco Ltd
Secretary	Secretary of the Department, or nominee
TSP	Total Suspended Particulate

1. INTRODUCTION

This *Air Quality Management Plan* (the Plan) has been prepared by Pacific Blue Metal Pty Ltd (PBM) in conjunction with R.W. Corkery & Co. Pty Limited for the Possum Brush Quarry (the Quarry). The Quarry is located approximately 2km west of the Pacific Highway at Possum Brush, 4km northwest of Failford and 5km northeast of Nabiac (**Figure 1**).

This Plan has been prepared in satisfaction of *DA Conditions 3(12) and 5(2)* of Development Consent (DA) 283/97¹. The Plan is one of six supporting documents for the Environmental Management Strategy. These six (6) supporting documents being:

- Air Quality Management Plan
- Blast Management Plan
- Landscape and Rehabilitation Management Plan
- Noise Management Plan
- Transport Management Plan
- Water Management Plan

¹ All conditions in Development Consent DA 283/97 are referred to as *DA Condition ...*

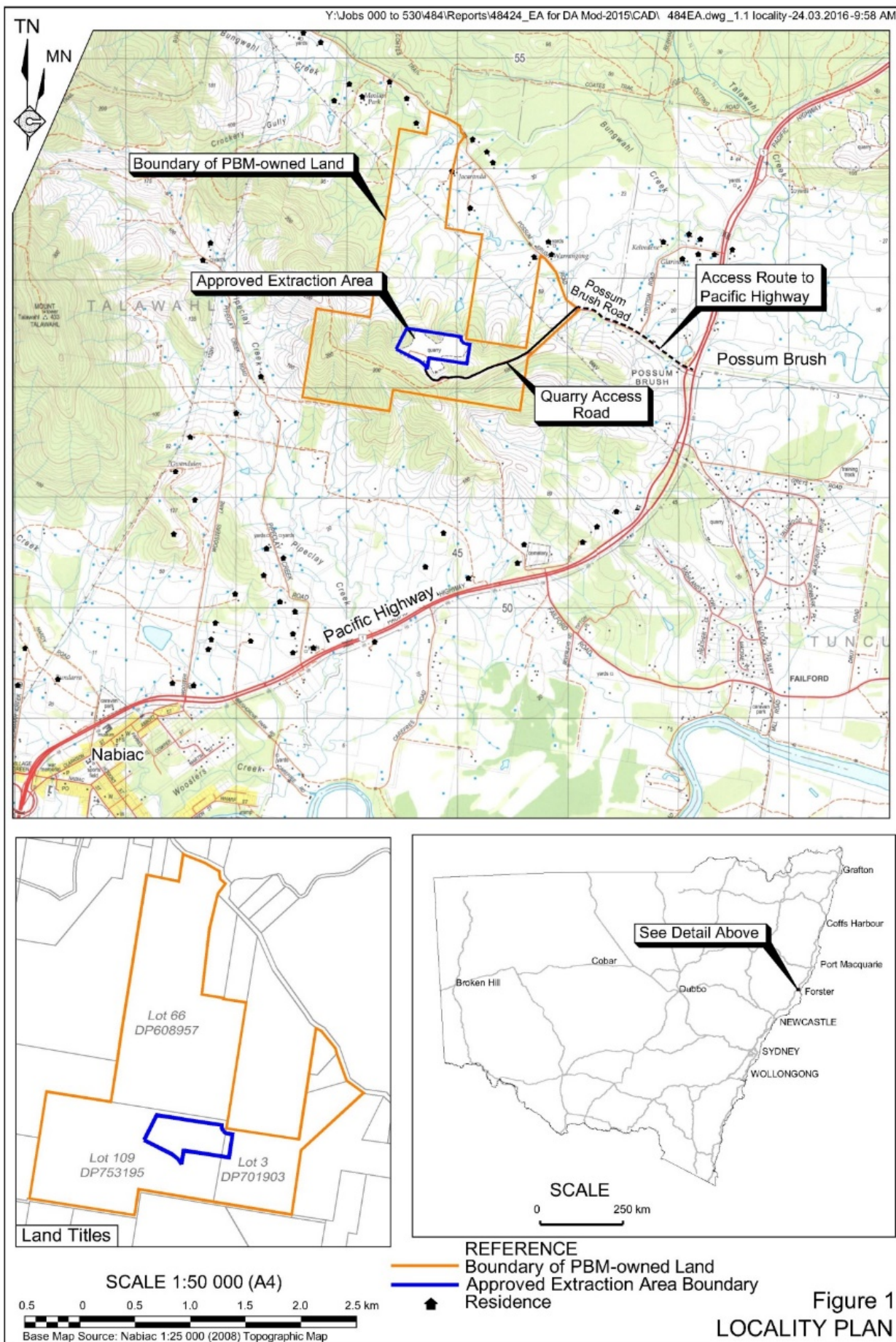

2. LEGAL AND OTHER REQUIREMENTS

2.1 DEVELOPMENT CONSENT

DA 283/97 was formally modified as Mod 4 by the Executive Director, Resource Assessments and Compliance as a delegate of the Minister of Planning on 1 April 2016 pursuant to Part 3A of the *Environmental Planning and Assessment Act 1979* (EP&A Act). Relevant air quality related conditions in DA 283/97 are reproduced in **Table 1** together with a reference to the section(s) of the Plan where each condition is addressed.

Table 1 Development Consent Requirements Relating to Air Quality

Schedule (Cond. No.)	Condition Requirement	Plan Section															
3(9)	<p>Air Quality Impact Assessment Criteria</p> <p>The Applicant shall ensure that all reasonable and feasible avoidance and mitigation measures are employed so that particulate matter emissions generated by the development do not cause exceedances of the criteria listed in Tables 4 at any residence on privately-owned land.</p> <p>Table 4: Air quality criteria</p> <table border="1"> <thead> <tr> <th>Pollutant</th> <th>Averaging Period</th> <th>^d Criterion</th> </tr> </thead> <tbody> <tr> <td>Particulate matter < 10µm (PM10)</td> <td>Annual</td> <td>^{a,d} 30µg/m³</td> </tr> <tr> <td>Particulate matter < 10µm (PM10)</td> <td>24 hour</td> <td>^b 50µg/m³</td> </tr> <tr> <td>Total suspended particulates (TSP)</td> <td>Annual</td> <td>^{a,d} 90µg/m³</td> </tr> <tr> <td>c Deposited dust</td> <td>Annual</td> <td>^b 2g/m²/month ^{a,d} 4g/m²/month</td> </tr> </tbody> </table> <p><i>Notes for Table 4:</i></p> <p>a. Cumulative impact (ie increase in concentrations due to the development plus background concentrations due to all other sources).</p> <p>b. Incremental impact (ie incremental increase in concentrations due to the development on its own, with zero allowable exceedances of the criteria over the life of the development).</p> <p>c. Deposited dust is to be assessed as insoluble solids as defined by Standards Australia, AS/NZS 3580.10.1:2003: <i>Methods for Sampling and Analysis of Ambient Air - Determination of Particulate Matter - Deposited Matter - Gravimetric Method</i>.</p> <p>d. Excludes extraordinary events such as bushfires, prescribed burning, dust storms, sea fog, fire incidents, or any other activity agreed to by the Secretary.</p>	Pollutant	Averaging Period	^d Criterion	Particulate matter < 10µm (PM10)	Annual	^{a,d} 30µg/m ³	Particulate matter < 10µm (PM10)	24 hour	^b 50µg/m ³	Total suspended particulates (TSP)	Annual	^{a,d} 90µg/m ³	c Deposited dust	Annual	^b 2g/m ² /month ^{a,d} 4g/m ² /month	5
Pollutant	Averaging Period	^d Criterion															
Particulate matter < 10µm (PM10)	Annual	^{a,d} 30µg/m ³															
Particulate matter < 10µm (PM10)	24 hour	^b 50µg/m ³															
Total suspended particulates (TSP)	Annual	^{a,d} 90µg/m ³															
c Deposited dust	Annual	^b 2g/m ² /month ^{a,d} 4g/m ² /month															
3(10)	<p>Operating Conditions</p> <p>The Applicant shall:</p> <p>a) implement best practice management to minimise the dust emissions of the development;</p> <p>b) carry out periodic air quality monitoring to determine whether the development is complying with the relevant conditions of this consent;</p> <p>c) regularly assess meteorological and air quality monitoring data and relocate, modify and/or stop operations on site to ensure compliance with the air quality criteria in this consent;</p> <p>d) minimise the air quality impacts of the development during adverse meteorological conditions and extraordinary events (see note d under Table 4); and</p> <p>e) minimise the area of surface disturbance and maximise progressive rehabilitation of the site,</p> <p>to the satisfaction of the Secretary.</p>	5 6 5, 7 5 5															

Table 1 (Cont'd)
Development Consent Requirements Relating to Air Quality

Schedule (Cond. No.)	Condition Requirement	Plan Section
3(11)	<p>Quarry-owned Land</p> <p>The Applicant shall ensure that all reasonable and feasible avoidance and mitigation measures are employed so that particulate matter emissions generated by the development do not cause exceedances of the criteria in Table 4 at any occupied residence on quarry-owned land unless:</p> <p>a) the tenant has been notified of any health risks associated with such exceedances in accordance with the notification requirements under Schedule 4 of this consent; and</p> <p>b) the tenant of any land owned by the Applicant can terminate their tenancy agreement without penalty at any time, subject to giving reasonable notice, to the satisfaction of the Secretary.</p>	5.1
3(12)	<p>Air Quality Management Plan</p> <p>The Applicant shall prepare an Air Quality Management Plan for the development to the satisfaction of the Secretary. In addition to the standard requirements for management plans (Condition 2 Schedule 5) this plan must:</p> <p>a) be submitted to the Secretary for approval by within three months of the date of approval of Modification 4, unless otherwise agreed by the Secretary;</p> <p>b) describe the measures that would be implemented to ensure:</p> <ul style="list-style-type: none"> – compliance with the relevant conditions of this consent; – best practice management is being employed; and – the air quality impacts of the development are minimised during adverse meteorological conditions and extraordinary events; <p>c) describe the proposed air quality management system; and</p> <p>d) include an air quality monitoring program that:</p> <ul style="list-style-type: none"> – is capable of evaluating the performance of the development; – includes a protocol for determining any exceedances of the relevant conditions of consent; – effectively supports the air quality management system; and – evaluates and reports on the adequacy of the air quality management system. <p>The Applicant shall implement the management plan as approved from time to time by the Secretary.</p>	This document
3(13)	<p>Meteorological Monitoring</p> <p>For the life of the development, the Applicant shall ensure that there is a suitable meteorological station operating in the vicinity of the site that complies with the requirements in the <i>Approved Methods for Sampling of Air Pollutants in New South Wales</i> guideline.</p>	6.6
3(14)	<p>Greenhouse Gas Emissions</p> <p>The Applicant shall implement all reasonable and feasible measures to minimise the release of greenhouse gas emissions from the site.</p>	5.3
4(1)	<p>As soon as practicable after obtaining monitoring results showing an:</p> <p>b) an exceedance of any relevant air quality criteria in Schedule 3, the Applicant shall send a copy of the NSW Health fact sheet entitled "Mine Dust and You" (as may be updated from time to time) to the affected landowners and current tenants of the land.</p>	8, 9

Table 1 (Cont'd)
Development Consent Requirements Relating to Air Quality

Schedule (Cond. No.)	Condition Requirement	Plan Section
5(2)	<p>The Applicant shall ensure that the Management Plans required under this approval are prepared in accordance with any relevant guidelines, and include:</p> <p>a) detailed baseline data;</p> <p>b) a description of:</p> <ul style="list-style-type: none"> – the relevant statutory requirements (including any relevant approval, licence or lease conditions); – any relevant limits or performance measures/criteria; and – the specific performance indicators that are proposed to be used to judge the performance of, or guide the implementation of, the project or any management measures; <p>c) a description of the measures that would be implemented to comply with the relevant statutory requirements, limits, or performance measures/criteria;</p> <p>d) a program to monitor and report on the:</p> <ul style="list-style-type: none"> – impacts and environmental performance of the project; and – effectiveness of any management measures (see (c) above); <p>e) a contingency plan to manage any unpredicted impacts and their consequences;</p> <p>f) a program to investigate and implement ways to improve the environmental performance of the project over time;</p> <p>g) a protocol for managing and reporting any:</p> <ul style="list-style-type: none"> – incidents; – complaints; – non-compliances with statutory requirements; and – exceedances of the impact assessment criteria and/or – performance criteria; and <p>h) a protocol for periodic review of the plan.</p> <p>Note: The Secretary may waive some of these requirements if they are unnecessary or unwarranted for particular management plans.</p>	<p>4</p> <p>2</p> <p>2</p> <p>4</p> <p>5</p> <p>6, 7</p> <p>8</p> <p>7</p> <p>8, 9, 10</p> <p>12</p>
5(7)	<p>The Applicant shall notify, at the earliest opportunity, the Secretary and any other relevant agencies of any incident that has caused, or threatens to cause, material harm to the environment. For any other incident associated with the project, the Applicant shall notify the Secretary and any other relevant agencies as soon as practicable after the Applicant becomes aware of the incident. Within 7 days of the date of the incident, the Applicant shall provide the Secretary and any relevant agencies with a detailed report on the incident, and such further reports as may be requested.</p>	10
5(8)	<p>The Applicant shall provide regular reporting on the environmental performance of the project on its website, in accordance with the reporting arrangements in any plans or programs approved under the conditions of this approval.</p>	11

2.2 ENVIRONMENT PROTECTION LICENCE

PBM currently hold Environment Protection Licence (EPL) 3393 for the operation of the Quarry.

This Air Quality Management Plan has been prepared in a manner that is consistent with the EPL. The specific criteria outlined in EPL 3393 relevant to air quality are detailed below in **Table 2**.

Table 2 EPL 3393 Air Quality Concentration Limits

Sampling Point	Pollutant	Criteria
Asphalt Plant (POINT 1 in EPL 3393)	Solid Particles	<50mg/m ³

3. OBJECTIVES AND OUTCOMES

Table 3 presents the objectives and key performance outcomes for this Plan and the Quarry.

Table 3 Objectives and Key Performance Outcomes

Objectives	Key Performance Outcomes
(a) To ensure compliance with the criteria of DA 283/97, EPL 3393 and reasonable community expectations.	(i) Compliance with all relevant criteria and reasonable community expectations, as determined in consultation with the relevant government agencies.
b) To implement air quality management and mitigation measures during all stages of the Project.	ii) All identified air quality management and mitigation measures are implemented to the extent required.
c) To implement an air quality monitoring program to establish compliance or otherwise with relevant criteria during all stages of the Project.	iii) All identified monitoring is undertaken in accordance with the relevant procedures and at the relevant intervals.
d) To implement a complaints handling and response protocol.	iv) Complaints (if any) are handled and responded to in an appropriate and timely manner.
e) To implement continual improvement for investigating, implementing and reporting on reasonable and feasible measures to reduce air quality impacts.	v) A continual improvement program has been implemented.
f) To implement an incident reporting program, if required.	vi) Incidents (if any) are reported in a timely manner.

4. BASELINE DATA

The following sections provide a summary of the ambient air quality baseline and predicted air quality levels that were assessed for the Quarry. These predictions are sourced from the air quality assessment prepared by Ramboll Environ Australia Pty Ltd (2015) to support the 2015 *Environmental Assessment* as part of the application for modification to DA 283/97.

Background Particulate Matter and Dust Depositional Data are also summarised.

4.1 WIND ENVIRONMENT

Annual and seasonal wind roses displaying wind speed and directions at the Quarry Site are shown in **Figure 2**. Winds are predominantly from the west in autumn, winter and spring, with strong winds over 10m/s originating mainly from the west. Somewhat lighter winds are predicted in summer, ranging from the north to the east and chiefly from the north-northeast. The local wind regime will be regularly reviewed and documented.

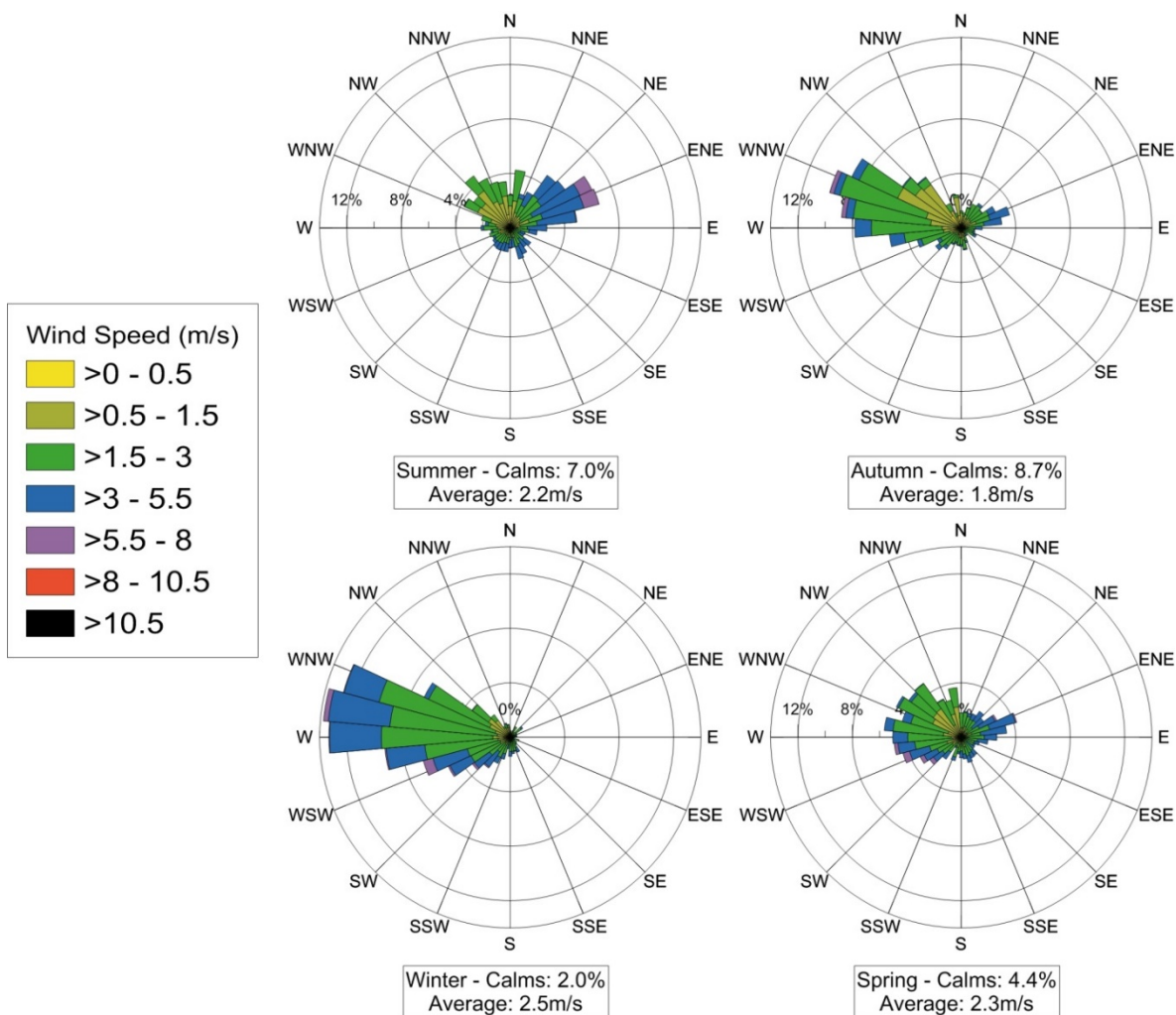

(Source: 2015 Environmental Assessment Air Quality Assessment [Ramboll Environ Australia] – Figure A1.2)

Figure 2
Calmet Seasonal Wind Roses – Quarry Site - 2014

4.2 AMBIENT AIR QUALITY

Relevant ambient air quality data for both dust deposition and airborne particulate matter for the Quarry was assembled by Ramboll (2015) as presented in **Table 4**

Table 4 Impact Assessment Criteria for Airborne Particulates

Pollutant	Averaging Period	Concentration ($\mu\text{g}/\text{m}^3$)	Reference
TSP	Annual	90	NSW EPA ^{(a)(b)}
PM ₁₀	24-hour	50	NSW EPA ^(a)
	24-hour	50 ^(d)	NEPM ^(c)
	Annual	30	NSW EPA ^(a)
PM _{2.5}	24-hour	25	NEPM ^(e)
	Annual	8	NEPM ^(e)

(a) NSW DEC, 2005 Approved Methods for Modelling
 (b) NSW EPA impact assessment criterion based on the subsequently rescinded NHMRC recommended goal
 (c) NEPC, 2003, National Environment Protection (Ambient Air Quality) Measure, as amended
 (d) Provision made for up to five exceedances of the limit per year
 (e) Advisory reporting goal issued by the NEPC (NEPC, 2003)

4.3 BACKGROUND PARTICULATE MATTER

No specific baseline data is yet available for the Quarry and its surrounds with respect to airborne dust. Ramboll (2015) relied upon data obtained from a monitoring station at Korora near Coffs Harbour. The daily varying (24-hour average) PM₁₀ and PM_{2.5} concentrations recorded at Korora are illustrated in **Figure 3**. It can be seen that the recorded 24-hour average PM₁₀ and PM_{2.5} concentrations fluctuate throughout the presented period.

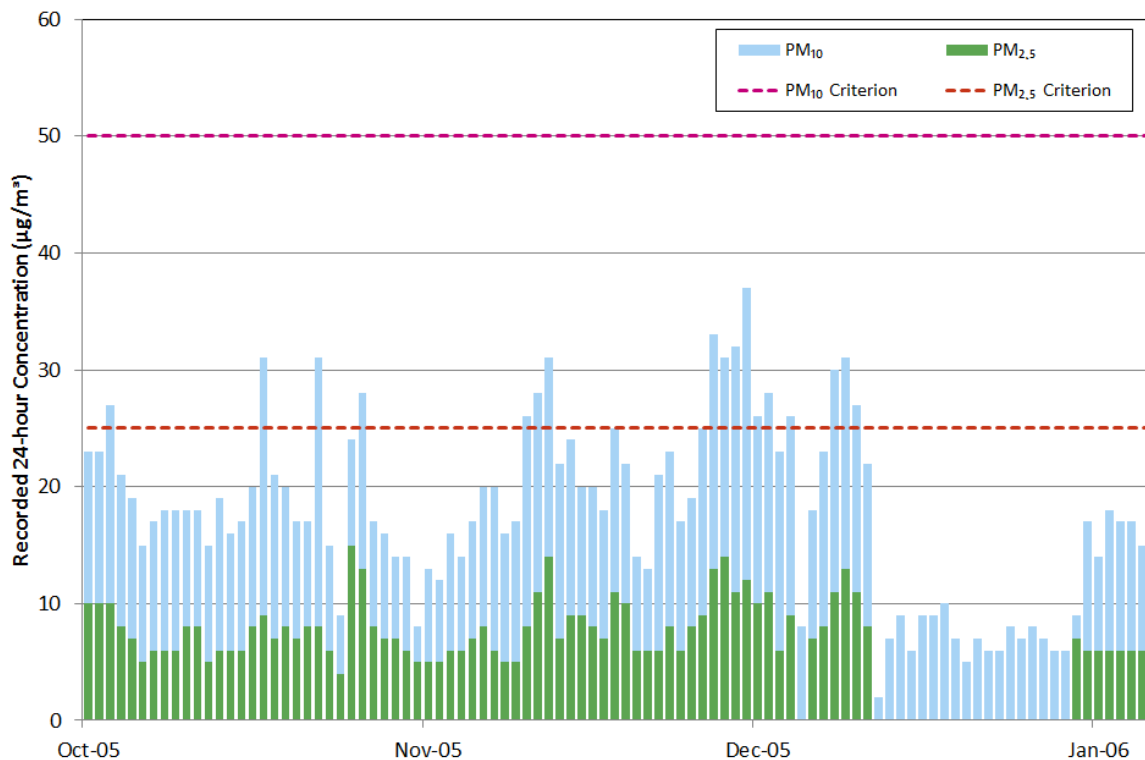

Figure 3 Korora Time-series 24-hour Average PM₁₀ and PM_{2.5} Concentrations– Oct 2005 to Jan 2006

4.4 DUST DEPOSITION DATA

Previous to PBM's Dust Monitoring program there was no dust deposition monitoring data available suitable to quantify baseline levels in the area surrounding the Quarry Site. Dust deposition around the Quarry Site was conservatively assumed to be 2g/m²/month.

Dust monitoring gauges installed at the two closest neighbours to the Quarry Site captured monthly depositional dust level between July 2017 – May 2019. The dust monitoring gauges are located at:

- 5 St Peters Close (Figure 3 Landowner Reference Number 8)
- 175 Possum Brush Road (Figure 3 Landowner Reference Number 2)

It is noted that the deposited dust monitoring undertaken during this two (2) year periods (when meteorological conditions were particularly dry) displayed very low depositional dust levels surrounding the quarry. As displayed in Table 6 the depositional dust levels are well below the assessment criteria of 4g/m²/month and well below the assumed background concentration level of 2g/m²/month.

A summary of the monitoring data is provided in **Table 5**.

Table 5 Depositional Dust Data 2017- 2019

Year	Month	R1 g/m ² /month	R2 g/m ² /month
2017	July	0.4	0.4
2017	August	0.8	1.2
2017	September	1.1	1.3
2017	October	n/a*	n/a*
2017	November	0.5	1.1
2017	December	0.6	1.8
2018	January	0.6	1.4
2018	February	0.3	1.2
2018	March	0.1	0.6
2018	April	0.4	0.8
2018	May	0.4	0.7
2018	June	0.2	0.3
2018	July	0.1	0.4
2018	August	0.4	0.6
2018	September	0.7	0.7
2018	October	0.4	0.8
2018	November	n/a**	n/a**
2018	December	1.5	1.3
2019	January	1.1	0.3
2019	February	2.0***	3.3***
2019	March	1.0	1.7
2019	April	0.1	1.7
2019	May	0.3	0.8
	AVERAGE	0.62	1.07

*Dust monitoring gauges destroyed in hail storm

** Dust monitoring not undertaken

*** Dust storms

R1 Due South of the quarry – farmland and forest.

R2 NNE of Quarry – farmland and forest, 35m from dirt road.

4.5 SURROUNDING RESIDENCES

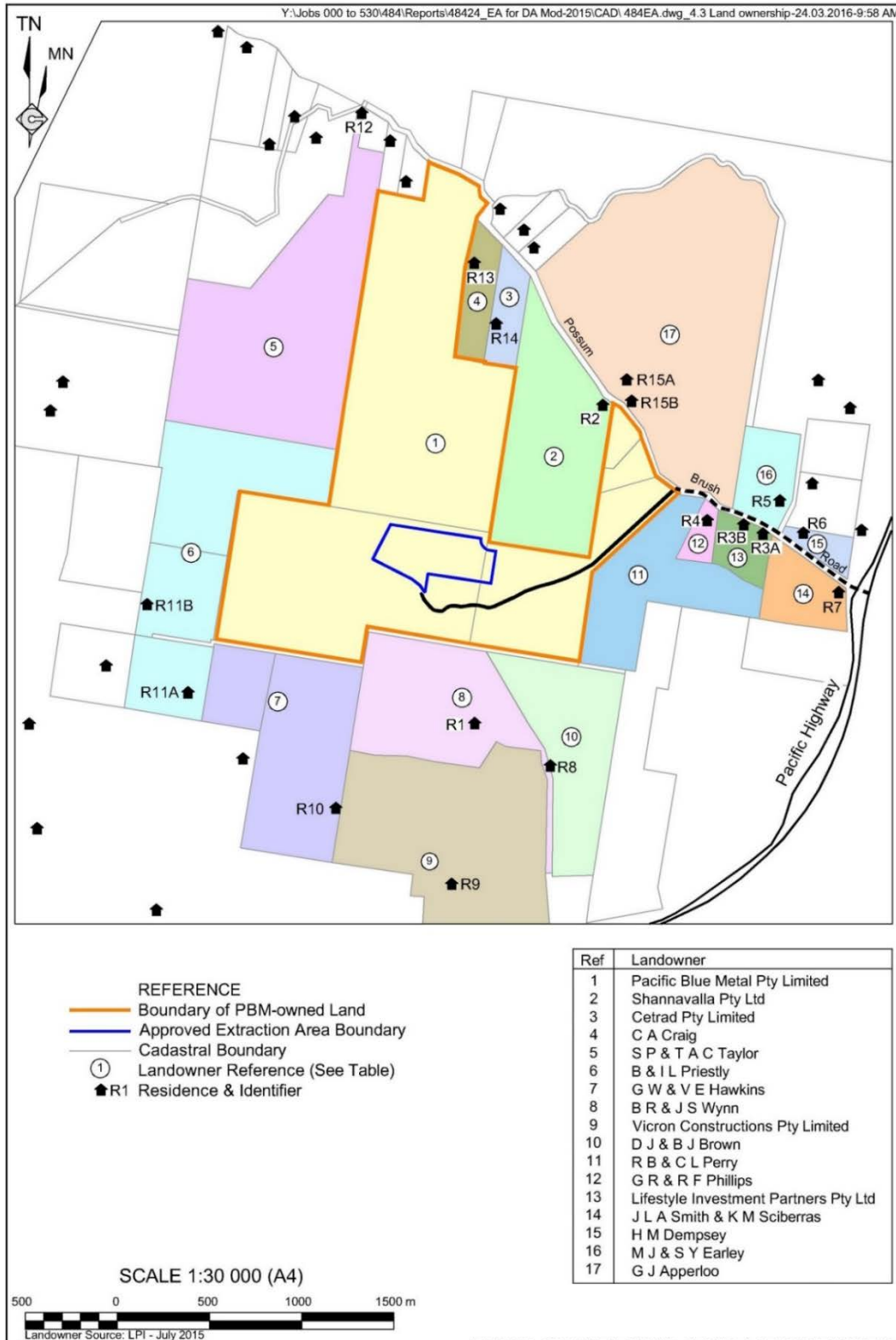

Figure 4 Land Ownership and Residences

5. AIR QUALITY CONTROL MEASURES

5.1 INTRODUCTION

The Air Quality Control Measures are designed to ensure that particulate matter emissions generated by the Quarry do not cause exceedances of the Air Quality criteria of DA *Condition 3(9)* and *EPL Condition L2.4* at any residence on privately-owned land.

Similarly, the measures will ensure that exceedances do not occur at any occupied residence on quarry owned land unless the requirements in DA *Condition 3(11)* are met (see Table.1 for full description of *Condition 3(11)*).

There are no occupied or tenanted residences on quarry owned land.

Figure 4 displays the location of residences surrounding the Quarry.

5.2 POTENTIAL AIR QUALITY IMPACTS

Potential air quality impacts include dust, exhaust and greenhouse gas emissions. The sources of these emissions would be as follows:

- Excavation and extraction – overburden excavation, extraction of weathered and fresh rock through drilling and blasting.
- Transportation – dust emissions from the materials being transported on site.
- Road dust – dust emissions from the internal unsealed roads as vehicles travel along them.
- Product stockpiles – dust emissions from stockpiles.
- Overburden stockpiles – dust emissions prior to revegetation.
- Exhaust and greenhouse gas emissions from trucks and machinery.

5.3 GREENHOUSE GAS EMISSIONS

The production of Greenhouse Gas emissions from the quarry will be reduced through implementation of the following measures:

- Efficiency Improvements - ensuring all fuel (diesel, natural gas, jet fuel and petrol) powered plant and equipment are optimally maintained.
- Alternative fuel schemes – installation of solar energy panels.
- Recovery and utilisation of C&D waste – providing products with lower embodied energy and lower CO₂ emissions.

5.4 DUST CONTROL PROCEDURES

Table 6 presents the air quality control measures that will be implemented to mitigate dust emissions from the quarrying activities.

Prior to the commencement of daily operations, the Quarry Supervisor will undertake an assessment of meteorological information to determine if any adverse wind conditions are predicted. If adverse conditions are predicted, the various activities planned for the day will be assessed to determine if further control procedures will be required to ensure that air quality compliance criteria are met. If compliance is unlikely to be achievable, activities will be temporarily suspended. The Supervisor will record the check of predicted meteorological conditions and any associated operational changes on the Daily Toolbox Record.

Table 6 Dust Control Measures

Source	Control Procedures	Personnel Responsible
General	<ul style="list-style-type: none"> Visually inspect operations for visible dust and adjust operations to reduce visible dust 	All personnel
Loading of extracted rock	<ul style="list-style-type: none"> Minimise the drop heights between front-end loader buckets and trucks carrying extracted materials. 	Loader Operator
Internal Roads	<ul style="list-style-type: none"> All unsealed roads and trafficked areas will be watered, as required, to minimise the generation of dust. Enforce a speed limit of 40km/hr on the Quarry access road and 25km/hr on all internal unsealed roads within the Quarry. Development of minor roads or tracks will be limited and the locations of these clearly defined. Obsolete roads will be ripped and re-vegetated. 	Site Supervisor or Quarry Manager
Product Stockpiles	<ul style="list-style-type: none"> Maintain product handling areas / stockpiles in a moist condition as required to minimise wind-blown and traffic-generated dust. 	Site Supervisor
Rehabilitation	<ul style="list-style-type: none"> Progressively rehabilitate finished areas, using reserved topsoil (where available), to maximise recolonisation with endemic species (further details available in the Landscape & Rehabilitation Management Plan) Install erosion/dust control where needed in inactive, but unfinished areas. 	Quarry Manager
Transportation of Products	<ul style="list-style-type: none"> Cover all loads prior to leaving the Quarry. Prohibit all vehicles and machinery from idling unnecessarily. 	All personnel

6. AIR QUALITY MONITORING

6.1 INTRODUCTION

DA 283/97 requires that an Air Quality Management Plan for the Quarry include the following.

- Details of air quality monitoring (*DA Condition 3(12)(d)*).
- Baseline air quality data (*DA Condition 5(2)(a)*).

Additionally, *DA Condition 3(13)* requires meteorological monitoring be undertaken. The following sub-sections are presented to satisfy these requirements.

It is acknowledged that air quality impacts from the Quarry have not been a concern with neighbours over the past 25 years.

Deposited dust monitoring was not required under previous consents nor the current Environment Protection Licence (EPL). The monitoring during the 2017-2019 period, at our two (2) closest neighbours (see **Figure 6**) has displayed that dust deposition in the surrounding environment is not an issue.

In light of low deposition dust levels and to bring the consent in line with the conditions of the EPL, the Department approved a cessation of monthly dust monitoring on 13 May 2019. Notwithstanding, should PBM receive a substantiated dust related complaint, monthly depositional dust monitoring will be resumed for a period of three (3) months at a location agreed to with the Department and the complainant and as per the methodology outlined in Sections 6.2-6.5.

For further details on PBM's complaints protocol see Section 9.

6.2 MONITORING EQUIPMENT

Should dust monitoring be required, equipment will be installed in accordance with the following standards and guidelines.

- *AS/NZS 3580.10.1: 2016 Methods for Sampling and Analysis of Ambient Air, Determination of Particulates – Deposited Matter – Gravimetric method.*
- *AS/NZS 35801.0:2016 Methods for sampling and analysis of ambient air – Guide to siting air monitoring equipment.*
- *NSW EPA Approved methods for the sampling and analysis of air pollutants in NSW (2022).*

6.3 PARAMETERS AND ASSESSMENT CRITERIA

Table 7 presents the relevant air quality assessment criteria that will apply to the Quarry at surrounding residences in accordance with *DA Condition 3(18)*.

Table 7 Background Air Quality Environment for Assessment Purposes

Air Quality Parameter	Averaging Period	Assumed Background Concentration / Level	Assessment Criteria
PM ₁₀	24-hour	Daily Varying	50 µg/m ³
	Annual	18 µg/m ³	30 µg/m ³
TSP	Annual	36 µg/m ³	90 µg/m ³
Deposited Dust	Annual	2g/m ² /month	4g/m ² /month

Deposited dust monitoring is a surrogate for demonstration of compliance with the PM₁₀ and TSP criteria in **Table 7**. If exceedances of deposited dust criteria are attributed to activities related to the Quarry, PM₁₀ monitoring will be introduced to quantify PM₁₀ contributions from the Quarry

6.4 MONITORING FREQUENCY

Depositional dust monitoring is undertaken upon receipt of an air quality complaint attributable to the quarry. To investigate the complaint, sampling will be undertaken for a period of three (3) months. During this time, dust deposition gauges will be sampled monthly in accordance with *AS/NZS 3580.10.1: 2016*, i.e. samples will be collected/changed over within two (2) working days of the first day of each month. The Compliance Manager will be responsible for ensuring sampling is undertaken in accordance with the relevant standards, guidelines and procedures outlined in Section 6.5.

6.5 DEPOSITED DUST MONITORING PROCEDURE

6.5.1 Introduction

Deposited dust sampling will be undertaken in accordance with the standards and guidelines listed in Section 6.2. The following presents the sampling procedures that will be implemented for sampling of dust deposition.

6.5.2 Sampling Equipment

Each deposited dust gauge will comprise the following components.

- A 2.4m steel post.
- A plastic sample holder.
- A glass sample container/bottle (2 litres).
- A 150mm diameter glass funnel (and rubber stopper).

Deposited dust gauges will be installed in accordance with *AS 3580.10.1: 2016* which requires the top of the glass funnel to be 2.0m + 0.1m above the surrounding ground level. It is also a requirement that the angle between the top of the gauge and surrounding vegetation is less than 30°. **Figure 5** displays an assembled gauge.

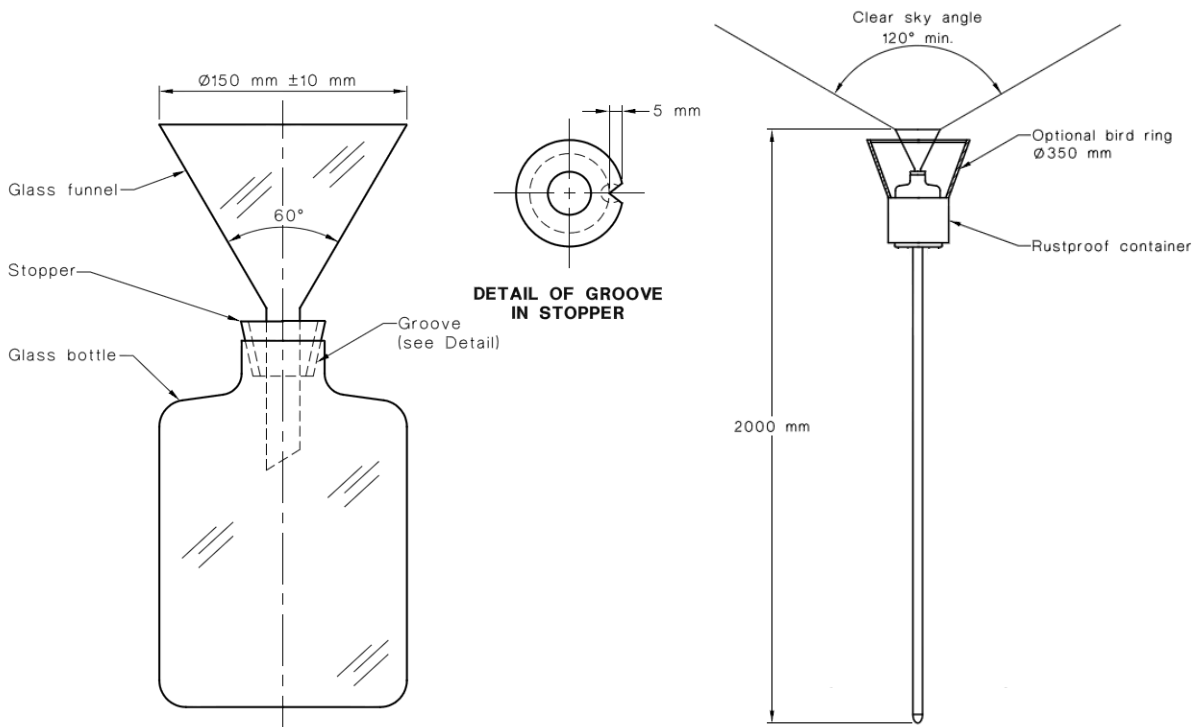

Source: AS 3580.10.1:2003 Methods for sampling and analysis of ambient air.

Figure 5
Typical deposited dust gauge

6.5.3 Sample Collection

When undertaking deposited dust monitoring samples are collected within two (2) days of the first day of each month (not being less than 28 or more than 32 days in total). The following equipment will be required during the monthly sample changeover.

- Deposited dust monitoring sheet and chain of custody form.
- Crate/container for sample container.
- Two (2) x glass sample containers (with copper sulphate CuSO_4 added at laboratory).
- Marker pen/ink pen.
- 50mL wash bottle.
- One (1) x container of distilled water.
- Clean cotton cloth.
- Narrow bottle brush.

- Spares kit:
 - glass funnel;
 - rubber stopper;
 - 1 litre bottle of CuSO₄ solution (available from laboratory); and
 - marker pen/ink pen.

6.5.4 Office Procedures

The following procedures are to be undertaken by the Compliance Manager prior to commencing the sampling program.

1. Check all new sample containers have the required quantity of copper sulphate added.
2. Check all equipment for use in the sample collection/changeover (Section 6.5.3) are present and functional.

6.5.5 Field Procedures

The following procedure will be implemented during collection/changeover of sample bottles.

1. Carefully remove the sample bottle and funnel from the sample holder (be careful of spiders, etc.).
2. Wash down the inside surface of the funnel with approximately 50mL of distilled water into the sample bottle using the bottle brush to loosen any deposited dust.
3. Remove the stopper and funnel from the sample bottle, taking care not to break the neck of the funnel and immediately place a cap on the sample bottle.
4. Complete the labelling of the sampling period on the sample flagon bottle by placing the date of collection on the bottle (see example below).
Possum Brush Quarry
DGI
Sampling Period
01/06/16 - 01/07/16
5. Place the stopper and cleaned funnel on the new bottle.
6. Ensure that the new bottle is properly numbered and the commencement date of the sampling period is recorded on the bottle (see example below).
Possum Brush Quarry
DGI
Sampling Period
– dd/mm/yy – dd/mm/yy
7. Replace the new bottle and funnel in the sample holder ensuring the top of the funnel is horizontal.
8. Ensure all relevant data and comments are written on the deposited dust Chain of Custody form before leaving each monitoring site.

It is always important to note whether there have been any changes in land use immediately adjacent to the gauge since the last collection period. Some changes may be slow, e.g. increasing height of nearby vegetation. It is also important to note if the sample has been contaminated by extraneous material including vegetation, bird droppings, insects, etc. This information needs to be recorded on the Chain of Custody form.

6.5.6 Sample Despatch

All samples despatched to the laboratory need to be accompanied by a deposited dust Chain of Custody form. It is important to establish a chain of custody for all documentation relating to the samples and the supply of the results, i.e.

- laboratory formally acknowledges receipt of samples and planned date for issue of draft results (if not received then follow up to check samples have not gone astray);
- draft results provided by laboratory (to be checked by Company personnel that they are appropriate and no laboratory errors have occurred); and
- receipt of final results (in a timely manner).

6.5.7 Data Recording and Reporting

Upon receipt of the laboratory results, the following will be undertaken.

- The results will be entered into a spreadsheet and compared with the guideline level of $4\text{g/m}^2/\text{month}$ and with previous results to identify any inconsistent results.
- In the event there are any excessive deposited dust levels, these need to be compared with the recorded wind speed and direction data (see Section 6.6) and any comments recorded during sample bottle changeover to potentially ascertain the source/s of the excessive levels. It is also worth reviewing the ash content on samples recording high total insoluble solid levels as low ash values indicate the dust to be of organic origin (e.g. pollen).

6.6 METEOROLOGICAL MONITORING

PBM has established a site meteorological station (**Figure 6**) to measure:

- temperature;
- rainfall;
- wind speed and direction; and
- solar radiation.

The meteorological station complies with the requirements in the Approved Methods for Sampling of Air Pollutants in New South Wales guideline.

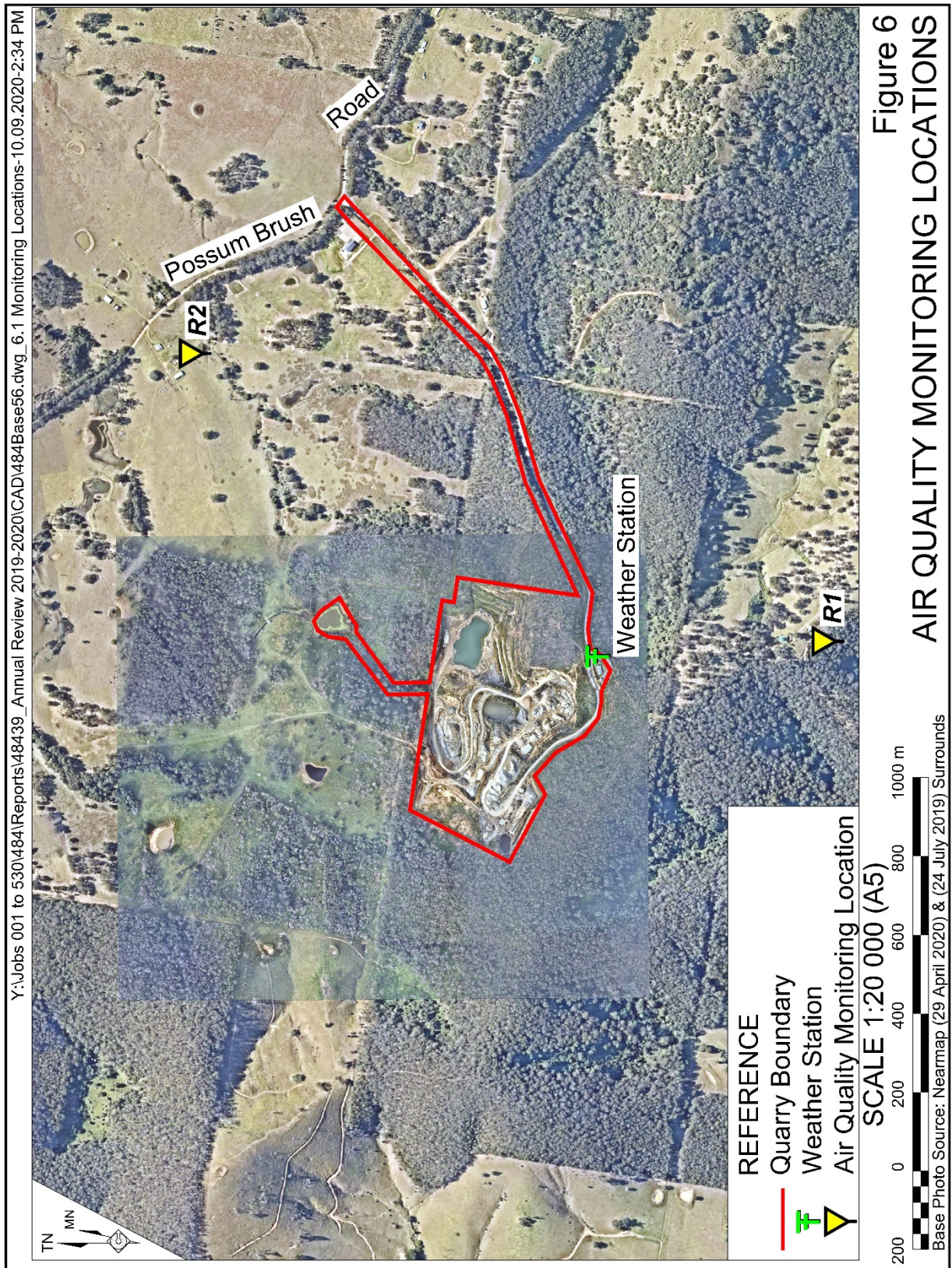

Figure 6: Air Quality Monitoring Locations

7. EVALUATION OF COMPLIANCE

PBM will evaluate compliance in accordance with the procedures detailed in the Section 7 of the Environmental Management Strategy.

In addition, all air quality monitoring results will be reviewed and tabulated by the Compliance Manager within seven (7) days of the receipt of data. The tabulated data will include an assessment of the monitoring results against the criteria identified in *DA Condition 3(9)*. A copy of the tabulated data will be included within each Annual Review.

In the event that the monitoring results approach the criteria identified in *DA Condition 3(9)*, the Quarry Manager or Compliance Manager will:

- review the meteorological data and Quarry-related activities for the same period;
- determine if the elevated dust levels/concentrations are Quarry-related; and
- if so, implement appropriate corrective and preventative actions, including further review of air quality monitoring data.

8. CORRECTIVE AND PREVENTATIVE ACTIONS

Section 8 of the EMS details the corrective and preventative actions to be taken in the event an exceedance of any relevant criteria or breach of condition(s) is identified.

In the event that air quality monitoring identifies an exceedance of the air quality criteria identified in *DA Condition 3(9)*, the exceedance will be investigated to determine the likely cause. The investigation will seek to determine:

- The date(s) and period of the exceedance and the wind speed and direction data during the monitoring period.
- Whether the exceedance of the criteria was directly related to one or more air quality sources associated with the Quarry or if any other factors contributed to the exceedance.
- The primary cause(s) of the incident.
- Any contributing factor(s) which led to the incident.
- Whether appropriate controls were implemented to prevent the incident.
- The most appropriate corrective and preventative measures that need to be implemented to prevent a recurrence of the incident.

In the event of an exceedance of the air quality criteria identified in *DA Condition 3(9)*, any dust affected landowners and/or tenants will be provided with a copy of the NSW Health fact sheet entitled “Mine Dust and You”

If it has been identified that the criteria have been exceeded, PBM will report and investigate the exceedance in accordance with the procedure identified in the EMS Section 10.

9. COMPLAINTS HANDLING AND RESPONSE

The *Environmental Management Strategy* as required by *DA Condition 5(1)* includes a detailed complaints management procedure (Section 9). This sub-section records the procedures that would be implemented following receipt of an air quality complaint.

Following receipt of any air quality-related complaint, PBM will implement the following procedure.

1. The complaint will be reviewed by the Compliance Manager or their delegate to determine the nature, date and time of the air quality emission. Relevant data shall be reviewed including quarry activities and meteorological data.
2. All complaints received by the quarry are to be reported to the Secretary, regardless of whether they are found to be attributable to the quarry or not.
3. Should the review determine the complaint is attributable to the quarry, initiate monitoring or other investigations to verify or otherwise any exceedance or non-compliance with approval condition(s).
4. For dust related complaints, monthly depositional dust monitoring may be resumed for a period of three (3) months at a location agreed to with the Department and the complainant and as per the methodology outlined in Sections 6.2 -6.5.
5. Should the investigation indicate an exceedance of the air quality criteria identified in *DA Condition 3(9)*, the Compliance Manager will notify the Secretary and will implement the procedures identified in *DA Condition 5(5)*.

Any dust affected landowners and/or tenants will be provided with a copy of the NSW Health fact sheet entitled “Mine Dust and You”. In addition, the Compliance Manager will continue to consult with the complainant, as required, in relation to the complaint.

6. Conduct a follow up interview with the complainant to determine their level of satisfaction with the response and the resultant outcome. In the event that any complainant does not consider that the response or reactions adequately address their concerns a formal dispute resolution process shall be entered into as per the *Environmental Management Strategy* Section 9.2.

All complaints would be recorded using a proforma complaints record sheet.

10. INCIDENT REPORTING

As per Environmental Management Strategy Section 10.

11. PUBLICATION OF ENVIRONMENTAL MONITORING INFORMATION

As per Environmental Management Strategy Section 11

12. PLAN REVIEW

As per Environmental Management Strategy Section 12

13. REFERENCES

Ramboll Environ Australia Pty Ltd (2015), *Air Quality Assessment for Possum Brush Quarry Stage 2 Operations and the Modification of Development Consent DA 283/97* prepared for R.W. Corkery & Co. Pty Limited, September 2015.